

# 'INBI' S-124 Mod. 'P-PU'

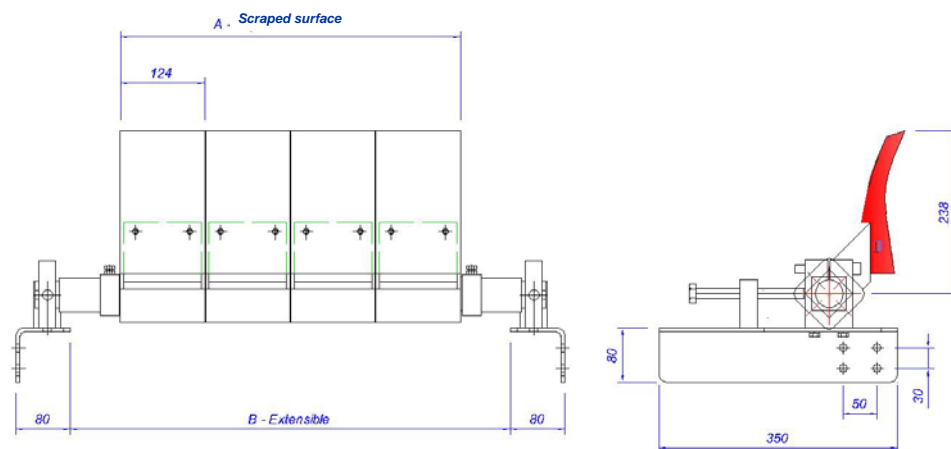

SERIE	MODEL	BELT WIDTH (mm)	Blades (quantity)	-A- Scraped surface	-B- minimum	-B- maximum
S-124	'P-PU'	400	3	372	740	952
		500	4	496	740	1.076
		650	5	620	800	1.200
		750	6	744	924	1.324
		800	6	744	924	1.324
		900	7	868	1.048	1.448
		1000	8	992	1.172	1.572
		1.200	9	1.116	1.296	1.696
		1.400	11	1.364	1.544	1.944
		1.600	12	1.488	1.688	2.088
		1.800	14	1.736	1.916	2.316
		2.000	16	1.984	2.164	2.564

### Notes:

- ◆ To get maximum 'B', should extend the axe.
- ◆ Available for another belt widths and special dimensions.
- ◆ Option of the total or partial manufacturing in INOX.
- ◆ This model allows to replace the Tungsten blades for Polyurethane blades.
- ◆ Available in ATEX version (explosives atmospheres)

### NOMENCLATURE

Serie (1), Model (2), Belt width (3), Versión (4): STANDARD, INOX, ATEX, DE -special dimensions-.

Example:

**S-124 P-PU 800 INOX**  
 (1) (2) (3) (4)

**Contact to our Technical Department for any doubt or consult that you require.**