

Beltsiflex

belts technologies

grupo peosa



THE BELTSIFLEX CONCEPT

Our belts, equipped with **sidewalls and cleats**, have been developed mainly for very steep inclined applications, **up to a gradient of 90°** (vertical plane).

As highly flexible conveyor belts, they facilitate **switching from horizontal to inclined conveying** (and viceversa); they can even be adapted to different layouts or arrangements to suit our client's needs.



- ▶ Beltsiflex **increases transport capacity up to 4 times** compared to other types of traditional belts on the same width range.
- ▶ It saves space by allowing **the vertical elevation of materials**, up to a gradient of 90°.
- ▶ This system allows for an **economical structural installation**, since it provides a single means of **conveying** materials, depending on the elevation height, where at least three conventional conveyors would have been necessary otherwise.
- ▶ Its **maintenance cost is lower** than that of a regular conveyor belts system.

TECHNOLOGICAL INNOVATION

- ▶ **The Beltsiflex® system** is an R&D project that achieves the required technology to produce conveyor belts thanks to a continuous automated process.

The security, stability and durability of the belts are achieved by hot vulcanizing the entire belt as a single unit.

- ▶ The levels of adhesion gained through hot vulcanizing are 15 times better than those offered by the traditional means of "cold splicing" used by some companies nowadays. Our hot vulcanized sidewalls and cleats belts have **no risk of dismembering** of the different elements due to their hot vulcanizing technology.
- ▶ Amongst other advantages, these belts can satisfy the demand for **lower diameters**, and long term storage does not affect the adherence of elements to the belt's base.

HOT VULCANIZING

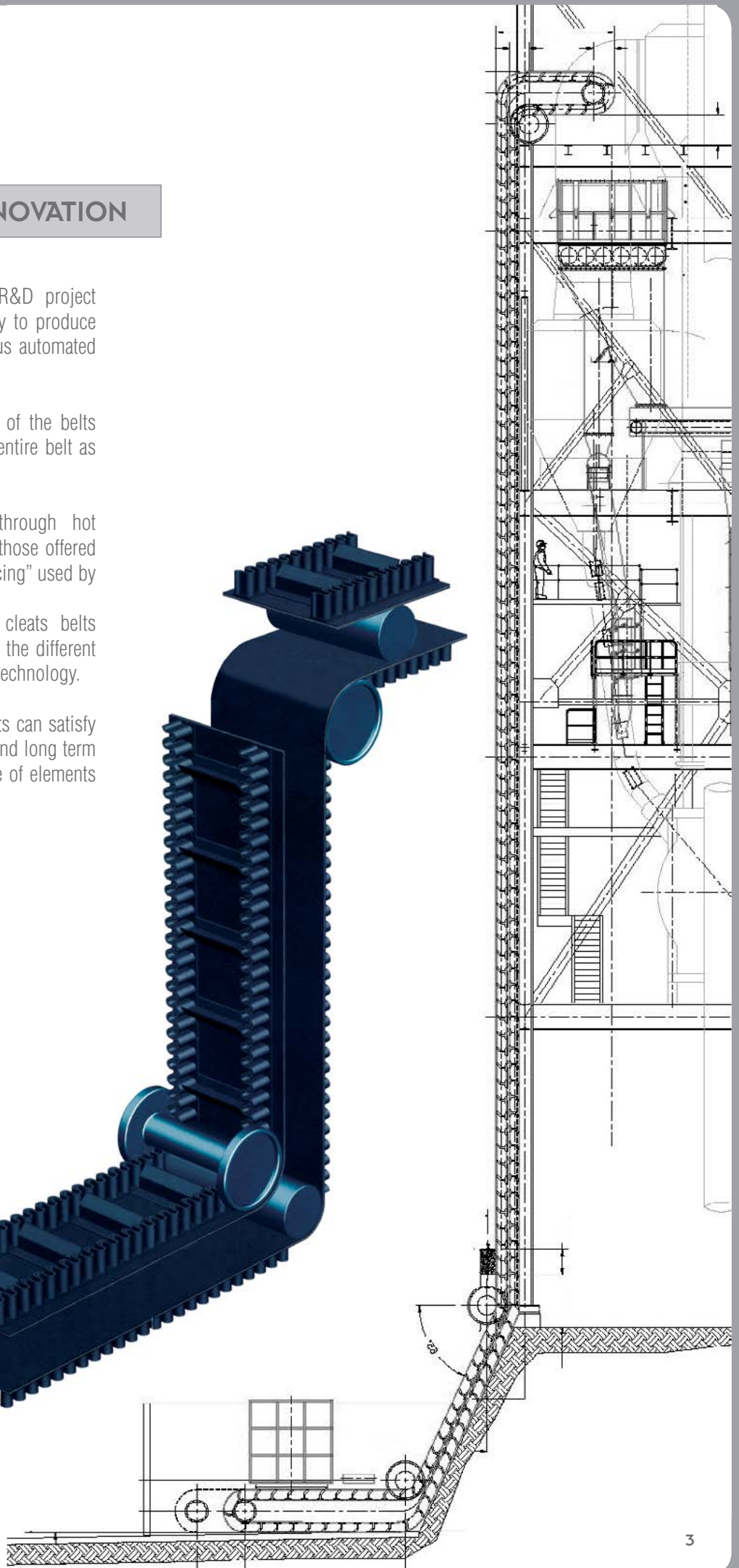

CLEATS

Cleats are always manufactured by press moulding. The quality or type of rubber used depends on the specifications of the product to be conveyed, fulfilling at all times the most demanding levels of wear resistance and abrasion strength.

Our cleats can be manufactured with or without fabric reinforcement. However, for cleats above 140 mm in height, we highly recommend the use of fabric reinforcement.



The recommended height of the cleats should be 10 to 20 mm lower than the height of the sidewalls.

Cleats type T, C, TC and TCFX differ mainly in their load capacity, and the choice will always depend on transportation needs.

Type TCFX consists of three elements: two bases joint to the belt and a cross cleat elevation screwed to the bases, which is always manufactured with fabric reinforcement.

RUBBER QUALITY:

N NORMAL QUALITY	G GREASE AND OIL RESISTANT	S FLAME RESISTANT	HR HEAT RESISTANT UP TO 150°C
-------------------------	-----------------------------------	--------------------------	--------------------------------------

CRITERIA FOR CLEAT CHOICE

In order to determine the dimensions of cleats when designing a Beltsiflex[®] belt, we use the same formula that applies in the volumetric calculations of a conventional belt. Nevertheless, we must consider where the materials to be transported are to be placed within the carrying area formed by the

cross cleats and the sidewalls; the grain size of the product will be of vital importance for good operation and functionality of the installed system.

For high granulometry products:

With the aim of avoiding the loss, leak or projection of material during transportation or accidents due to obstruction, it is necessary to pay attention to three selection criteria, always dependant on maximum granulometry. These criteria will always be the minimum measures to be increase according to the transport capability desired.

1. Spacing between cleats:

The minimum distance between cleats must be twice the maximum grain size.

2. Cleat width:

The width of cleats must be at least 2.5 times the maximum grain size.

3. Cleat height:

EAs for the minimum height of the cleats, two aspects must be considered when making a choice:

- a) Once again, maximum grain size
- b) The angle of inclination of the belt:

It is recommended that you follow these criteria:

Angle of inclination: $0 \div 60^\circ$

Cleat height: $0.75 \div 1.0 \times$ grain size ("g")

Angle of inclination: $60 \div 75^\circ$

Cleat height: $1.0 \div 1.2 \times$ grain size ("g")

Angle of inclination: $75 \div 90^\circ$

Cleat height: $1.5 \times$ grain size ("g")

The height of the sidewall must always be in excess of between 10 and 20 mm than of the selected cleat.

For vertical belting, "TC" or "TCXF" type cleats must be used.

Products with low grain size :

The material conveyed within the pockets of the belt never takes up 100% of their carrying volume. When calculating the capacity of the pockets, we must always consider a 75% load, as indicated in the attached figure. When the granulometry of the materials to be carried is low, the shortest possible spacing between cleats should be selected in order to achieve maximum efficiency; depending on the type of cleat chosen, the spacing will be different.

The necessary belt width is determined according to belt dimensions, height and desired load capability.

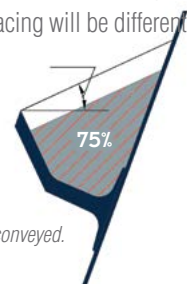
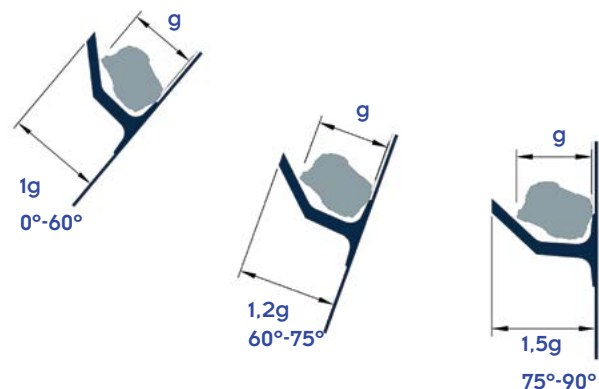
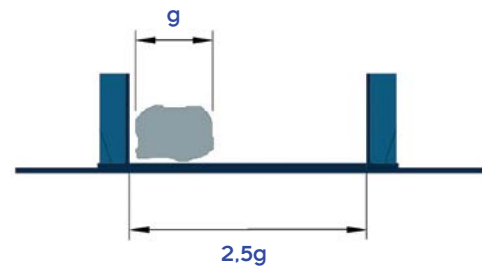
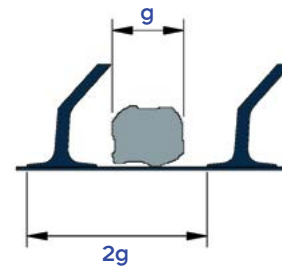

Dynamic capability angle.
Depends on the material to be conveyed.

TYPE OF CLEATS

TYPE	HEIGHT mm	BASE WIDTH mm	WEIGHT kg/m	MAX. LENGTH PRODUCED mm	RUBBER TYPE	ø DRIVING AND RETURN DRUM mm	ø mm INFLEXION PULLY	FABRIC REINFORCEMENT	CLEAT SHAPE
T-30	30	80	1,10	3400	N/G/S/RC	180	180	Without Fabric Reinforcement	 T
T-40	40	80	1,30	3400	N/G/S/RC	180	180		
T-50	50	80	1,45	3400	N/G/S/RC	180	180		
T-60 / TF-60	60	100	2,35	3400	N/G/S/RC	200	315	With and without Fabric Reinforcement	 C
T-75 / TF-75	75	100	2,55	3400	N/G/S/RC	200	350		
T-90 / TF-90	90	100	2,80	3400	N/G/S/RC	240	375		
T-110 / TF-110	110	100	3,10	3400	N/G/S/RC	280	375		
T-140 / TF-140	140	150	5,95	2400	N/G/S/RC	350	560		
T-160 / TF-160	160	150	6,45	2400	N/G/S/RC	400	640		
T-180 / TF-180	180	150	6,75	2400	N/G/S/RC	450	720		
C-75 / CF-75	75	85	1,80	3400	N/G/S/RC	200	300		
C-110 / CF-110	110	95	2,7	3400	N/G/S/RC	280	350		
TC-75 / TCF-75	75	80	2,00	3400	N/G/S/RC	200	300		
TC-90 / TCF-90	90	110	2,65	3400	N/G/S/RC	240	325		
TC-110 / TCF-110	110	110	3,10	3400	N/G/S/RC	280	350		
TC-140 / TCF-140	140	150	5,8	2850	N/G/S/RC	350	560		
TCF-160	160	150	6,45	2850	N/G/S/RC	400	640	With Fabric Reinforcement	 TCF
TCF-180	180	150	7,10	2850	N/G/S/RC	450	720		
TCF-220	220	160	8,50	2850	N/G/S/RC	550	880		
TCF-230	230	170	8,90	2850	N/G/S/RC	600	960		
TCF-240	240	170	9,15	2850	N/G/S/RC	600	960		
TCF-260	260	170	9,80	2850	N/G/S/RC	650	1040		
TCF-280	280	170	10,4	2850	N/G/S/RC	700	1120		
TCXF-240 SLIM	240	280	16,8	2400	N/G/S/RC	650	1040	With Fabric or Metal Reinforcement	 TCXF TCXF SLIM TXF
TCXF-260 SLIM	260	280	17,3	2400	N/G/S/RC	700	1120		
TCXF-280 SLIM	280	280	17,8	2400	N/G/S/RC	750	1200		
TCXF-280	280	280	19,70	2400	N/G/S/RC	750	1300		
TCXF-330	330	280	23,70	2400	N/G/S/RC	900	1500		
TCXF-360	360	280	25,00	2400	N/G/S/RC	1000	1750		
TCXF-460	460	280	31,70	2400	N/G/S/RC	1300	2200		
TCXF-560	560	280	36,10	2400	N/G/S/RC	1500	2650		
TXF-380	380	280	24,00	2400	N/G/S/RC	1000	1650		

SPECIAL TYPES	HEIGHT mm	BASE WIDTH mm	WEIGHT kg/m	MAX. LENGTH PRODUCED mm	RUBBER TYPE	ø DRIVING AND RETURN DRUM mm	ø mm INFLEXION PULLY	FABRIC REINFORCEMENT
TL-35	35	35	1,20	2850	N/G/S/RC	180	180	With or without Fabric Reinforcement
TL-55	55	40	1,70	2850	N/G/S/RC	180	200	
TXF-220 / TXF-240	220 / 240	170	13,00	2700	N/G/S/RC	600	960	
CL-45	45	60	1,30	2400	N/G/S/RC	180	180	

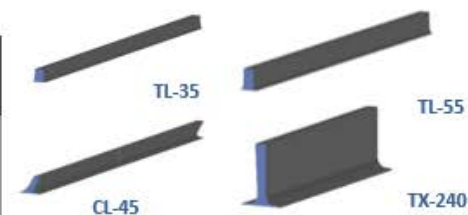

„The references with F letter= production with fabric reinforce.

„The indicated diameters are calculated for type N quality, they are merely for reference.

*The value of the drum diameter selected will be the most restrictive value according to several criteria: minimum diameter due to the sidewalls, minimum diameter due to the cleat, minimum diameter due to the belt and minimum diameter due to the tensions subjected.

Beltsiflex[®]

belts technologies



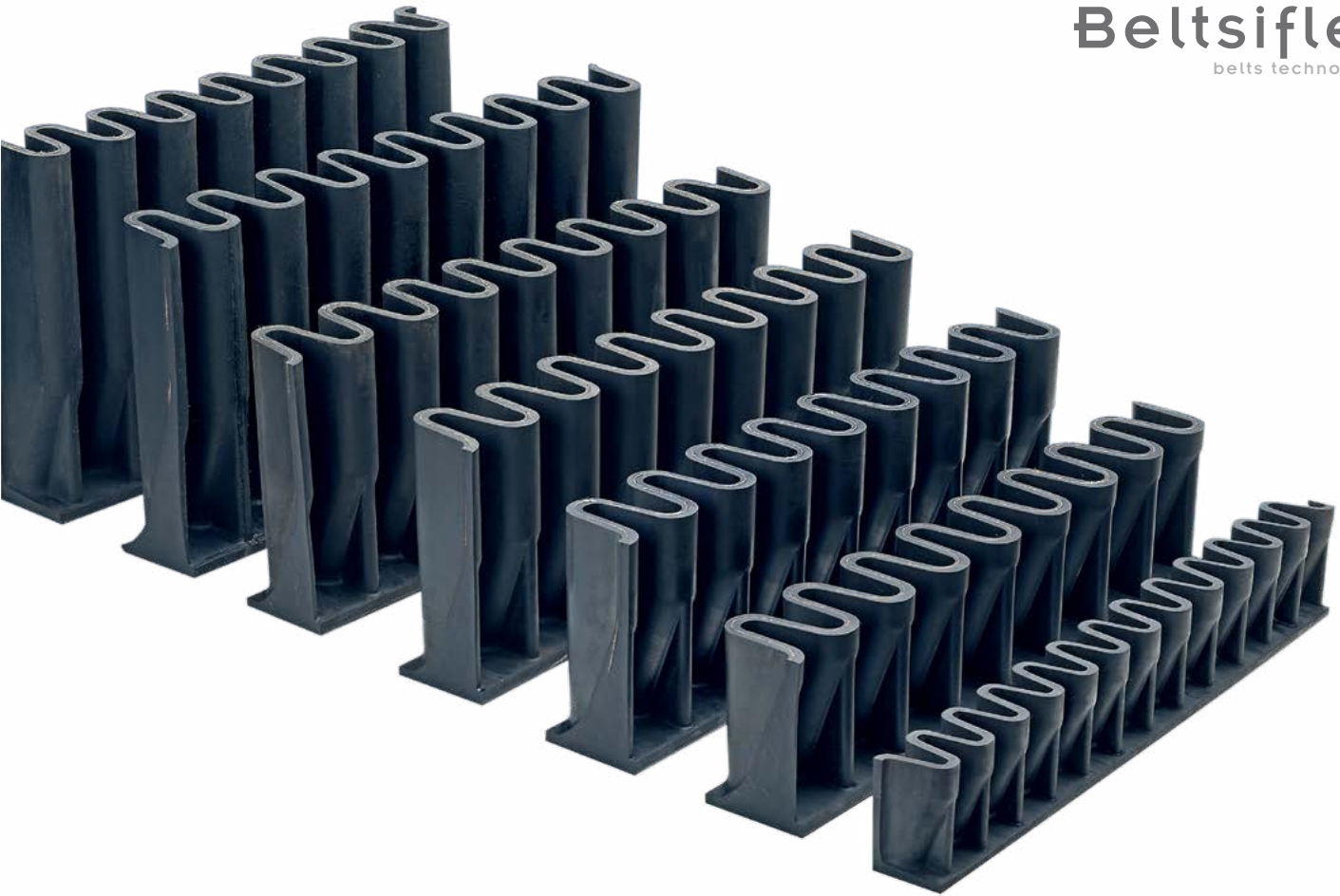

TYPES OF SIDEWALLS

Sidewalls are manufactured in a wide range of heights, from 40 mm up to 600 mm.

All sidewalls can be produced with a fabric reinforcement insert, particularly recommended for heights over 140 mm and necessary for heights of 160 mm and above.

The design of our sidewalls offers great vertical resistance, which adds greater stability to the belt and maintains a high degree of flexibility while allowing it to adapt to lower diameter pulleys.

- It is important to observe the minimum diameters required in order to achieve the longest service life possible.

We generally recommend the following:

$D1 = 4 \times \text{sidewall height}$
 $D2 = 2,5 \times \text{sidewall height}$

Depending on the quality of the rubber, it's necessary that you get a separate calculation for each specific project.

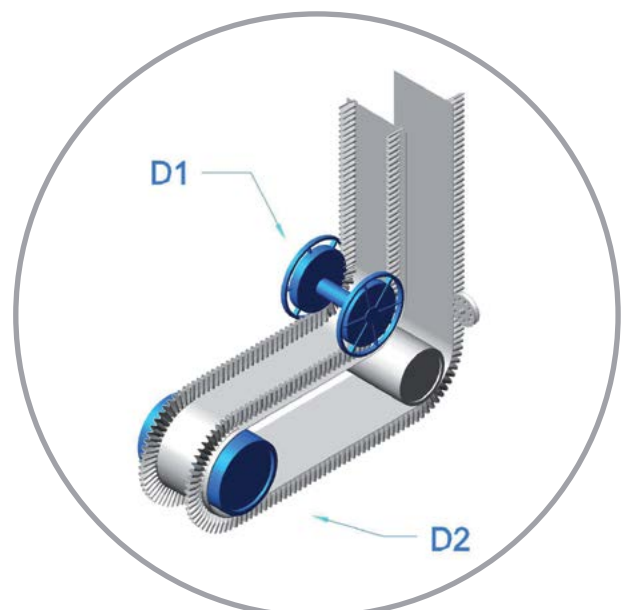

TYPES OF SIDEWALLS

TYPE	HEIGHT mm	BASE WIDTH mm	WEIGHT kg/m	MAX. LENGTH PRODUCED m	RUBBER TYPE	PITCH	ø DRIVING AND RETURN DRUM mm	ø mm INFLEXION PULLEY	FABRIC REINFORCEMENT
N-40	40	40	1,0	500	N/G/S/HR	47	180	200	WITHOUT FABRIC REINFORCEMENT
N-60	60	40	1,20	400	N/G/S/HR	47	180	240	
N-80	80	40	1,40	300	N/G/S/HR	47	230	320	
S-80 / SF-80	80	50	1,80	300	N/G/S/HR	50	200	320	WITH AND WITHOUT FABRIC REINFORCEMENT
S-100 / SF-100	100	50	2,30	300	N/G/S/HR	50	250	400	
S-120 / SF-120	120	50	2,70	300	N/G/S/HR	50	300	480	
S-140 / SF-140	140	50	3,10	250	N/G/S/HR	50	350	560	
BSF-120	120	75	4,00	250	N/G/S/HR	60	300	480	
BSF-140	140	75	4,60	200	N/G/S/HR	60	350	560	WITH FABRIC REINFORCEMENT
BSF-160	160	75	5,20	150	N/G/S/HR	60	400	640	
BSF-180	180	75	5,80	125	N/G/S/HR	60	450	720	
BSF-200	200	75	6,40	125	N/G/S/HR	60	500	800	
BSF-220	220	75	7,00	125	N/G/S/HR	60	550	880	
BSF-240	240	75	7,60	125	N/G/S/HR	60	600	960	
BSF-250	250	75	7,90	125	N/G/S/HR	60	625	1000	
BSF-260	260	75	8,20	125	N/G/S/HR	60	650	1040	
BSF-280	280	75	8,80	125	N/G/S/HR	60	700	1120	
BSF-300	300	75	9,40	125	N/G/S/HR	60	750	1200	
MSF-300	300	115	15,05	100	N/G/S/HR	83	1000	1250	WITH FABRIC REINFORCEMENT
MSF-350	350	115	17,50	100	N/G/S/HR	83	1100	1400	
MSF-400	400	115	19,90	100	N/G/S/HR	83	1200	1650	
MSF-500	500	115	24,75	100	N/G/S/HR	83	1500	2050	
MSF-600	600	115	29,60	100	N/G/S/HR	83	1800	2500	

*The references with **F** letter= production with fabric reinforce.

*The indicated diameters are calculated for type **N** quality, they are merely for reference and it is necessary a calculation for each specific project.

*The value of the drum diameter selected will be the most restrictive value according to several criteria: minimum diameter due to the sidewalls, minimum diameter due to the cleat, minimum diameter due to the belt and minimum diameter due to the tensions subjected.
For any questions, please contact Siban.

RUBBER QUALITY:

N	NORMAL QUALITY
G	GREASE AND OIL RESISTANT
S	FLAME RESISTANT
HR	HEAT RESISTANT UP TO 150°C

CROSS STABILITY BELTS

SIBAN has developed a cross stability rigid belt base for the construction of the Beltsiflex belts, necessary for the system performance optimisation. We can offer different constructions to suit the specifications of each installation.

The use of cross stability rigid belts offers **significant advantages**:

- ▶ Provides **better support** on the return strand.
- ▶ **Avoids the wear and tear** of sidewalls and cleats.
- ▶ **Prevents the crowning** of the carrying surface at deflection points.
- ▶ **Prevents the loss** of driving power.
- ▶ It is only possible to use a standard belt with no cross stability in small constructions without deflection points.

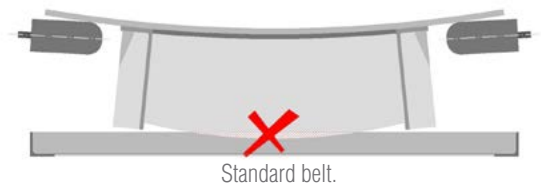
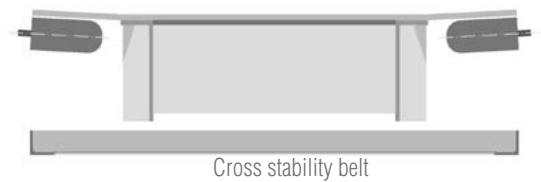

In order to adapt **Beltsiflex belts** to the characteristics of the materials to be transported, we offer a **variety of rubber compounds** used in the covers of the base belts, all manufactured according to **DIN** standards.

RUBBER QUALITY:



N	NORMAL QUALITY
G	GREASE AND OIL RESISTANT
S	FLAME RESISTANT
HR	HEAT RESISTANT UP TO 150°C

TYPES OF CROSS STABILITY BELTS

CROSS STABILITY RIGID FABRIC BELTS • TYPE XE

Manufactured with **fabric plies**, they are produced using the same **Beltsiflex**[®] elevated belting systems technology. They provide greater stability than the commonly used EP fabrics (polyester - nylon) by adding to these one or two **monofilament fabrics** to achieve the rigidity most suitable for the belt's characteristics.

All XE, XC and XS belt types are manufactured in the following rubber compound varieties:

- N** NORMAL QUALITY
- G** GREASE AND OIL RESISTANT
- S** FLAME RESISTANT
- HR** HEAT RESISTANT UP TO 150°C

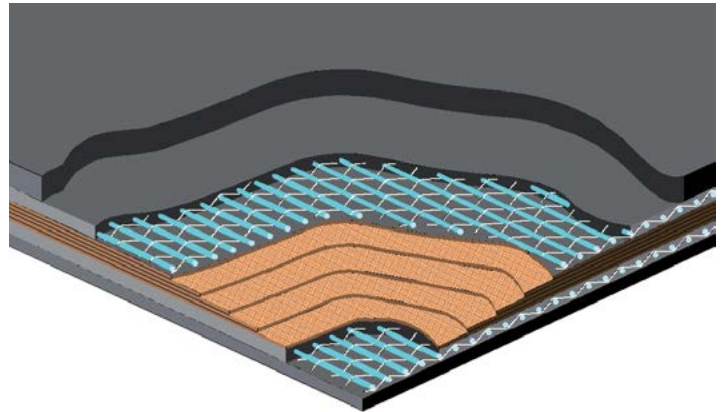

MAXIMUM WIDTH IN STANDARD MANUFACTURING: 2400 mm

We manufacture belts with different covers and widths other than standard ones on request.

TYPE	COVERS		THICKNESS mm	WEIGHT kg/m	N. OF FABRICS		ø DRIVING AND RETURN DRUM mm	ø mm INFLEXION PULLEY
	TOP mm	BOTTOM mm			TENSIONING	WEAVE		
XE250/2	TR 3	TR 1.5	9.5	11.87	2	2	315	350
XE400/3	TR 4	TR 2	12	14.87	3	2	400	500
XE500/3	TR 4	TR 2	12.50	15.8	3	2	500	600
XE630/4	TR 4	TR 2	13.50	17.3	4	2	600	750
XE800/4	TR 4	TR 2	14	17.7	4	2	800	1000
XE1000/5	TR 4	TR 2	15.2	18.9	5	2	1000	1200
XE1250/5	TR 4	TR 2	16.5	20.54	5	2	1200	1400

**The indicated diameters are merely for reference, being necessary to calculate them for the specifications of each specific project.*

TYPES OF CROSS STABILITY BELTS

CROSS STABILITY RIGID FABRIC BELTS TYPE XC

Manufactured with **fabric plies**, they are produced using the same **Belsiflex®** XE type technology but differ from this in that their rigidity is achieved by inserting one or two **metal cords across the belt**.

This type of belt is recommended when the rigidity needed is not satisfied by the XE type. It is particularly indicated for the transportation of **large productions and heavy duty applications** requiring significant width dimensions.

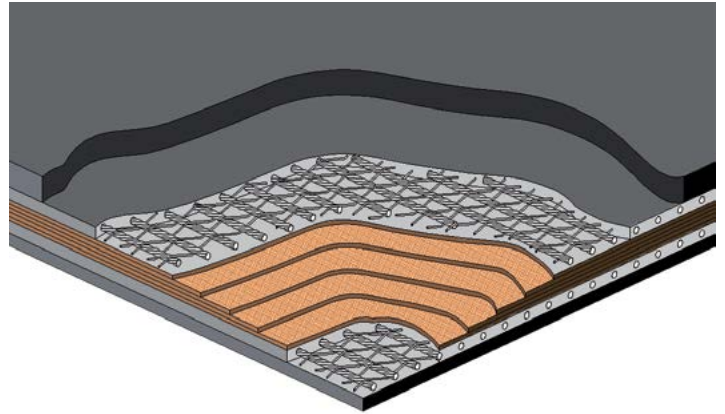

CROSS STABILITY RIGID METAL BELTS TYPE XS

This belt differs from type XC in that it also incorporates **metal cord tensioning along the belt** and is used for the construction of big installations where the belt, not only supports high productions, but is also of **large dimensions**. The **elongation** values of this type of belts are nearly null.

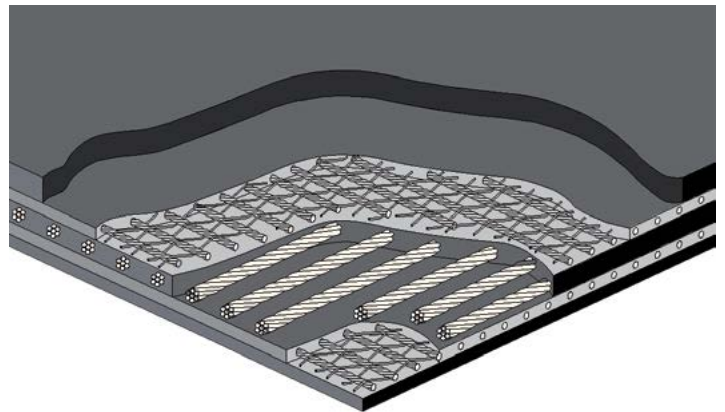

FIX • FASTENING FITTINGS

Lateral fastening fittings are made of nylon and allow **fixing the sidewalls to the cross cleats**. Their use is recommended from BSF-140 heights and above.

Each fix set comprises two parts made of nylon, depending on the type of belt, and 4 screws in galvanised Steel



TYPE OF FIX	SIDEWALL TYPE	SCREW
NYLONFIX - 65	SF120 / BSF120	M5 x 60
	BSF140	
NYLONFIX - 80	BSF140	M6 x 80
	BSF160	
	BSF200	
NYLONFIX - 120	BSF240	M6 x 80
	BSF260	
	BSF280	
	BSF300	
NYLONFIX - 150	MSF300	U bolts M10
	MSF350	
	MSF400	
NYLONFIX - 170	MSF500	U bolts M12
	MSF600	

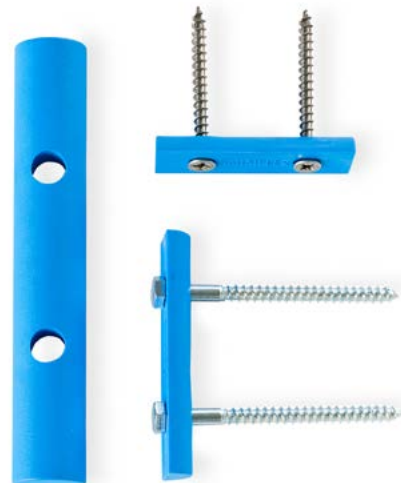

BLINKERS

Blinkers are **fitted in-between the sidewall and the cleats profile**. Their use is recommended only when the **material to be transported is very fine and dusty**.

Blinkers avoid the transfer of materials through the small holes between the sidewalls and the cleats.



ALIGNING WHEELS

The Beltsiflex® system provides 2 technologies for producing its alignment wheels. These wheels can be produced entirely in damping rubber or entirely in steel with a rectified rolling zone in rubber.

We recommend the use of these wheels for their convenience when it comes to installing the belt and in situations where the belt tends to divert itself from the centre, and requires rectification of its working position. However, they must only be considered as a secondary security measure.

For maximum efficiency, they must be placed **before drums and deflection points.**



HOT SPLICING KIT

Siban's hot splicing kit is available in different grades: Normal Quality, Heat resistant quality, Oil resistant quality, Flame Retardant quality and white. These qualities can be offered for Textile and Steel cord belts. The hot splicing kit consists of:

- ▶ COVER RUBBER, filler material with specific characteristics for the running areas of the conveyor belt.
- ▶ UNCURED INTERPLY RUBBER, with outstanding properties of adhesion, tear resistance and flexibility providing a really good performance to the joints.
- ▶ RUBBER SOLUTION, the suitable and necessary product for hot vulcanized conveyor belts.

Depending on the width of the conveyor belt, the client will be provided with the appropriate materials for making the splicing kit.



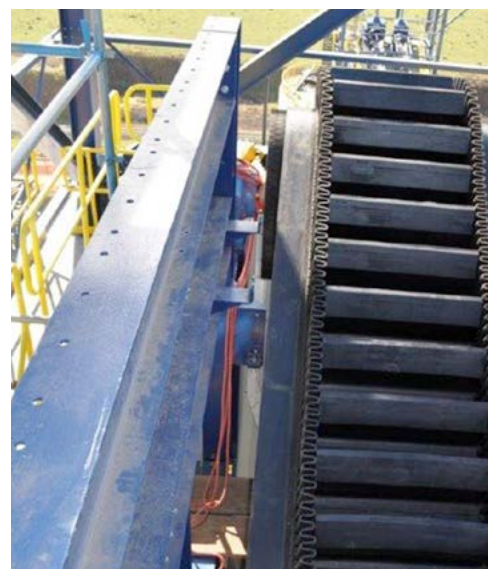
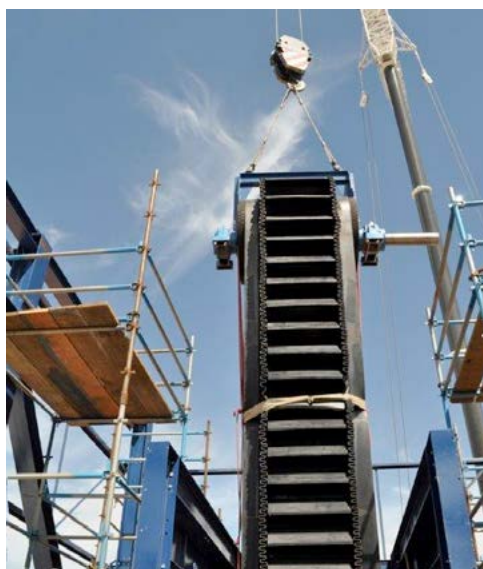
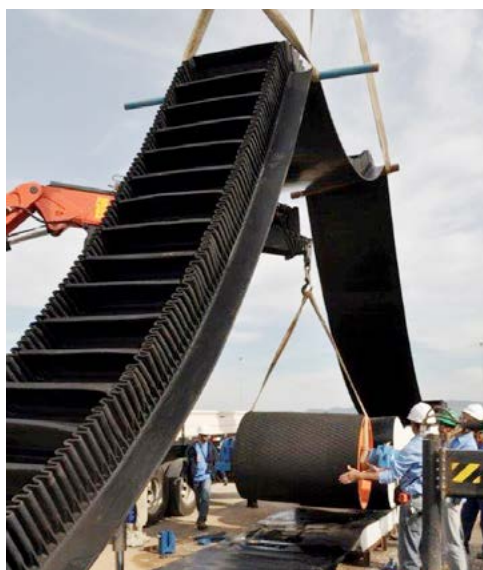

QUESTIONNAIRE FOR BELT CALCULATION

COMPANY _____

PERSON _____ EMAIL _____

TEL. _____ FAX _____

Please indicate whether the belt you require is:

A BELT FOR REPLACEMENT

A BELT FOR A NEW INSTALLATION

INSTALLATION RELATED DATA

Distance between axes m
 Length of bottom horizontal section a m
 Length of top horizontal section c m
 Lift height b m
 Length of inclined section m
 Angle of inclination α (°)
 Angle of load β_2 °
 Angle of discharge β_1 (°)
 Belt speed m/s

MATERIAL

Capacity required tn/h
 Maximum grain size mm
 Material moisture content %
 Density gr/cm³

BELT RELATED DATA

Belt width mm
 Cleat type
 Cleat length mm
 Cleat pitch mm
 Sidewall type
 Free side insets mm

SPECIALS FEATURES

Temperature °C
 Grease or oil presence
 Explosive atmosphere
 Material's natural angle of slide °
 Ambient moisture content %

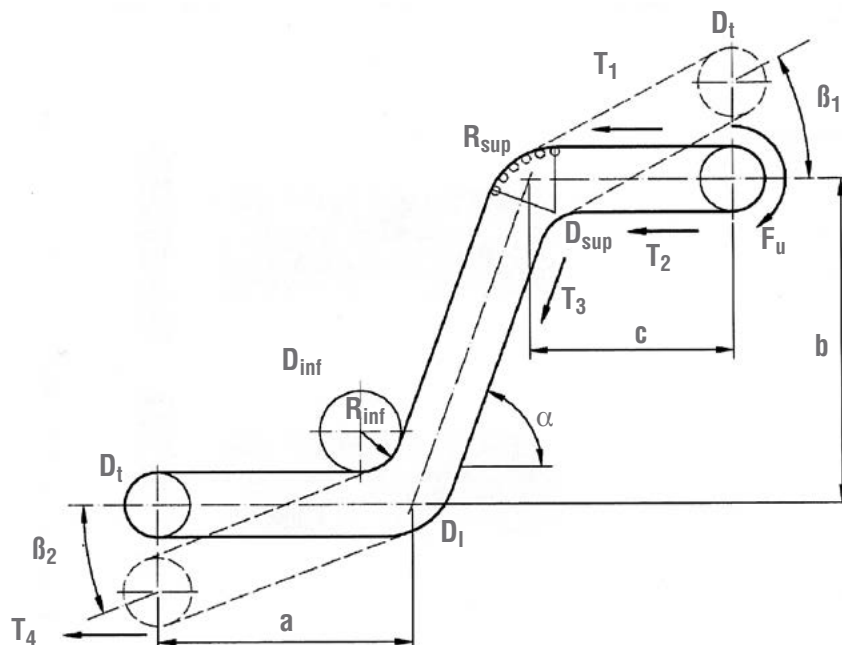



Beltsiflex[®]

belts technologies



grupo peosa

www.siban.com

SPAIN

Parque Empresarial Abra Industrial Parc.2.1.2
48500 Gallarta - Abanto y Ciervana
Vizcaya
Tlf: +34 94 437 50 00
Fax: +34 94 438 61 11
siban.bilbao@siban.com

Basaldea 25, P.I. Jundiz
01015 Vitoria
Alava
Tlf: +34 945 29 29 46
Fax: +34 945 29 29 41
siban.vitoria@siban.com

Gudarien Kalea, 8
48970 Basauri
Vizcaya
Tlf: +34 946526114
Fax: +34 946526115
lyrsa@lyrsasl.com

PORTUGAL

Recta do Mindelo,
Estrada Nacional, 13 km 16
4486-851 Mindelo
Tlf: +351 252 66 90 40
Fax: +351 252 67 23 01
siban.portugal@siban.com

GERMANY

Friedrich-Ebert-Str. 134
47800 Krefeld
Tlf: +49 (0) 2151 3250703
Fax: +49 (0) 2151 3250704
Mov: +49 (0)1525 3955588
arthur.lubinski@siban.com

AUSTRIA

Eckpergasse 40/2/11
1180 Wien
Mov: +43 676 4670767
Fax: +34 94 4386111
siban@belt-austria.com

UNITED KINGDOM

DN22 7GR Retford
Nottinghamshire
Tlf: +44 1777 712696
Fax: +44 1777 712770
Mov: +44 7970 846741
simon.drohan@siban.co.uk

REPUBLIC OF ECUADOR

Parque Empresarial El Zauce km.11,5
Avda. A- Manzana E - Solar 10 - Local 12
Centros de Bodegas 4
Guayaquil
Tlf: +593 42 100145 / +593 87227173
Fax: +593 42100145
goiko@siban.com

SIBAN PEOSA CHILE SPA

Av. Cristóbal Colón 7000 Dpto. C-96
Las Condes
Santiago de Chile
Tlf: +569 81 620 790
hernan.vidal@siban.com

MEXICO

Genova 1135-102, Palermo
45200 Zapopan - Jalisco
Tlf: +52 33 4000 7877
Fax: +52 33 4000 7877
Mov: +52 133 1622 2527
carlos.garcia@siban.com