

## FILTERBELT

Rubber drainage belt for HBF  
(horizontal vacuum belt filter)



**THE DRAINAGE BELT IS THE MOST IMPORTANT COMPONENT OF EVERY FILTRATION PLANT.**

Every single belt is designed and tailored to meet all the requirements related to the plant process data.

Until today we have produced and sold more than one thousand filterbelt all over the world.

That thanks to investments for the construction of new plants, development of new production systems, research for new material and components. The result is that today our company is among the world leading manufacturers of filtration belts.

South Africa  
Ezulwini Mine-Uranium

*customizing your needs.*

# DRAINAGE BELTS TECHNICAL ASSISTANCE

Our Technical Department and Lab staff is always available to support our customers for every topic related to:

## PRE-SALES SERVICE

- Designing of the most suitable belt.
- Choice of the most suitable rubber compound according to process parameters - also supported by immersion tests in the slurry.
- Compatibility between drainage belt base and lateral flanges.
- Suggestions regarding the most suitable structure: textile fabrics type, total thickness and grooving according to type of material to be filtrated, temperature process, slurry composition, washings, pulleys diametre.



Rubber laboratory

## Immersion test procedure

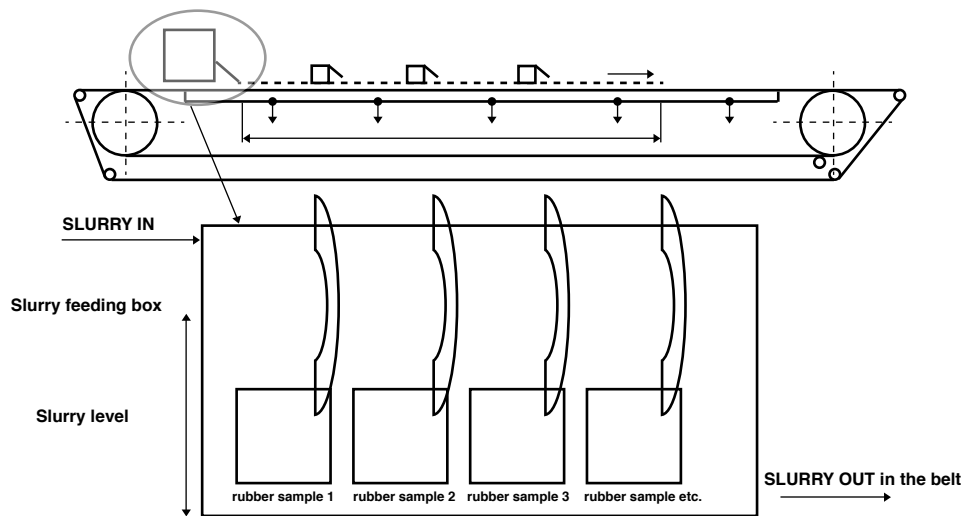

## AFTER-SALES SERVICE

- Suggestions for the installation of drainage belts, e.g.: correct procedure for dismantling of the old drainage belt, correct installation of the new one, correct tensioning, tracking, alignment.
- Support for repairment in case of mechanical damages that could happen to the belt during its life.

All the manufacturing steps of each filter are carefully monitored by our technical staff and all the components of the product are tested in our laboratory. We are also supported by CERISIE, the most important Italian center of research and development of elastomers, for specific research:

- choice of raw material with special properties for particular applications
- development of compounds for specific uses
- tests of accelerated deterioration and resistance to natural and chemical agents.



We are very proud to supply our technical support and we believe that an open relationship with our customers, based on a spirit of partnership, is the condition to a mutual success.

# APPLICATIONS AND AVAILABLE COMPOUNDS

Filterbelt can be obtained in the following rubber compounds according to process parametres:

- NB – Natural Rubber
- SBR-MT and SBR-HT – Styrene Butadiene Rubber, medium and high temperature
- EPDM – Ethylene-Propylene Diene Monomer
- EPM – Ethylene-Propylene Monomer
- BIIR – Bromobutyl
- CIIR – Chlorobutyl
- CR – Neoprene
- EPDM/BIIR – Mix of EPDM/Bromobutyl
- CSM – Hypalon
- NBR – Nitrile rubber
- CDB – Food Quality Rubber (white rubber)

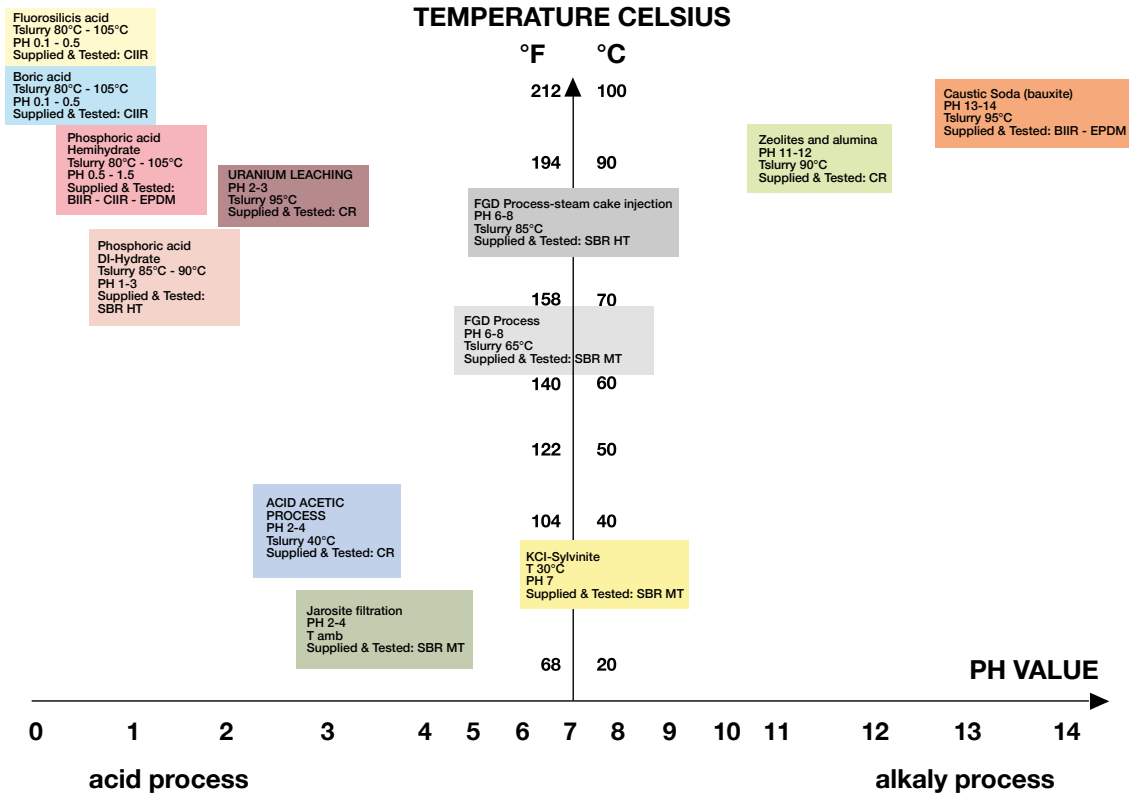

Here below the main processes with a small selection among several applications:

## Chemical processing

- Aluminium fluoride
- Calalyzer
- Calcium
- Gypsum (FGD flue gas desulfurization)
- Ores leaching
- Phosphates
- Magnesium
- Nichel salt
- Peroxide
- Phosphoric acid (hemy hydrate and de hydrate)
- Boric acid
- Zinc carbonates
- Zeolite

## Mineral processing

- Ores dewatering
- Quartz
- Uranium
- Copper
- Lead
- Golden and silver
- Titanium dioxide
- Sylvine

## Food

- Acetic acid
- Calcium
- Lactic acid
- Citric acid
- Maltose
- Sugar
- Mycellium

Our laboratory is always available in preparing samples of rubber compound to carry out immersion tests directly in the slurry during filtration process. After samples analysis and results comparison we will be able to determine the most suitable compound with the better performances. Our laboratory and technical staff are also available to assist customers in choosing the correct compound for new applications.

*customizing your needs.*



## DESIGN AND STRUCTURES

The drainage belts can be supplied in different designs. Here are the most common:

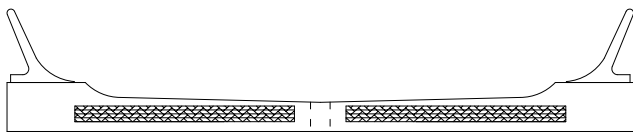

**With lateral straight curb** (height 75 or 125 mm) applied by hot vulcanization or by cold bonding by means of specific cements

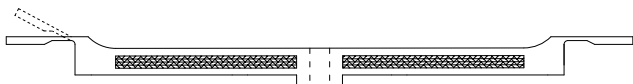

**With lifting flat curbs** and inner rubber guide obtained in a single piece by mold

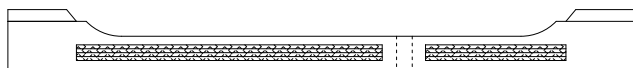

**With flat trapezoidal curbs** applied by cold bonding by means of specific cements

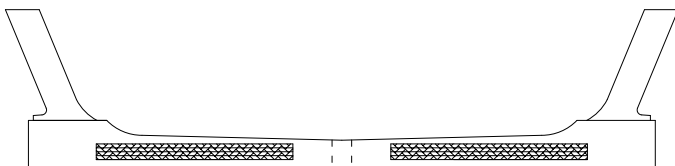

**With corrugated lateral curbs** (height up to 130mm) applied by cold bonding by means of specific cements



Example of textile carcass Filterbelt with transverse grooves

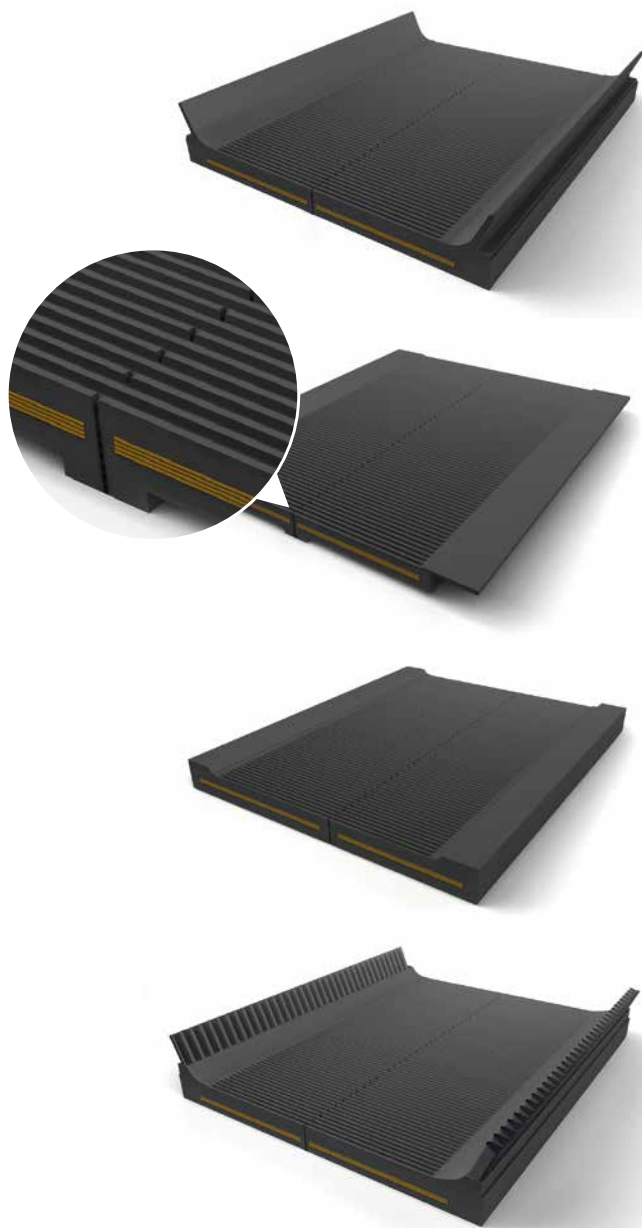

Filterbelt are produced in the following versions:

- **endless, by hot vulcanized splice**
- **open rolls to be spliced on site by hot vulcanization or by cold bonding**
- **with applied or loose lateral curbs according to the dimensions of the drainage belt**

These are the main textile structures:

630/3 3 tele EE200 warp and weft in polyester  
800/4 4 tele EE200 warp and weft in polyester  
1000/4 4 tele EE250 warp and weft in polyester  
1000/5 5 tele EE200 warp and weft in polyester

It is possible to customize “Filterbelt” design by means of different textile fabrics (i.e. EP polyester/polyamide fabrics).

All the drainage belts have a central and lateral area in all rubber to prevent contact between the textile carcass and corrosive filtrates and to ensure durability overtime.

**Achievable thickness:** typically up to 40 mm but with possibility of getting even higher values.

**Achievable widths:** up to 3320 mm in one piece and up to 4700 mm with longitudinal splice by hot vulcanization

**Achievable length:** over 100 m

## GROOVING AND DRILLING

Grooves can be realized:

- Flat (no inclination between centre and edges)
- Sloped (with inclination between centre and edges)

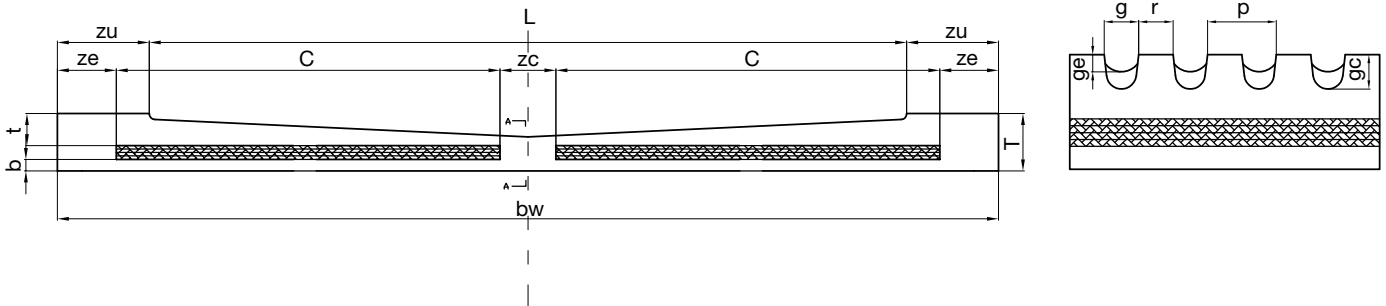

DATA:

<b>bw</b>	belt width	<b>L</b>	groove length
<b>T</b>	belt thickness	<b>zu</b>	edge zone without grooves
<b>zc</b>	central free carcass zone	<b>ge</b>	groove depth near edge
<b>C</b>	carcass width	<b>gc</b>	groove depth in the centre
<b>ze</b>	edge rubber zone	<b>g</b>	groove width
<b>b</b>	bottom cover thickness	<b>r</b>	rib width
<b>t</b>	top cover thickness	<b>p</b>	groove pitch

Do not hesitate to contact us in case you need customized belt finishing (different pitch, groove width, rib width, groove height).

### Holes

They can be obtained in 2 different types: round or oval-shaped and in each groove or every two rubber ribs/strand mainly in the following dimensions:

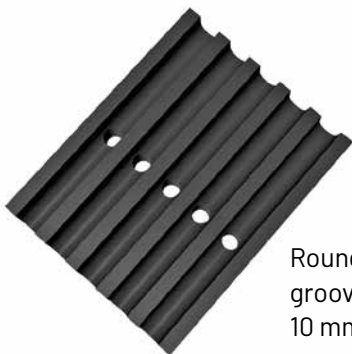

Round drilling holes in every groove: diameter from 10 mm to 25 mm

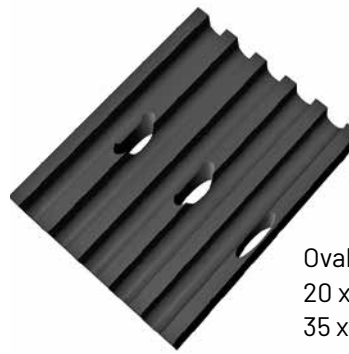

Oval slot every two rubber ribs/strand  
20 x 10 mm – 30 x 20 mm  
35 x 20 mm – 45 x 9 mm

*customizing your needs.*

# RUBBER DRAINAGE BELTS FOR PHOSPHORIC ACID PLANTS

The ever increasing demand of phosphates for agricultural industry has encouraged the growth of different production units for phosphoric acid and derivatives (phosphogypsum) with a consequent increase of rubber drainage belts request. Processes related to this production are mainly two, according to the quality of extracted rocks, achievable concentrations, temperature, concentration of H<sub>2</sub>SO<sub>4</sub>. Different anti-foaming and scaling agents can be used depending on the type of organic rocks use in the phosphoric acid process. Their presence is very critical being the cause of swelling phenomena and premature failure of the belt.

## HEMY HYDRATE PROCESS

For this process we normally supply 2 types of rubber compounds: **EPDM** and **A NEW COMPOUND THAT IS A MIX OF BUTYL / EPDM**. Physical-mechanical characteristics (hardness, elongation at break, breaking strength, modulus) of this last compound will remain stabler over the time granting better performances.



## DE-HYDRATE PROCESS

SBR HT compound is recommended for this application, that is less chemically aggressive and with lower temperatures compared to the hemy-hydrate process.

Our experience is confirmed by the excellent performance of our drainage belts running on many different plants all over the world and by past immersion tests comparisons done in the facilities of the most important phosphoric acid producers.

Our Technical Department is available to any suggestion about the use of the most appropriate rubber compound according to process type, also proposing rubber interaction tests with specific chemical slurry components (e.g. scaling agent or defoamer) or immersion tests to carry out directly in the slurry.

Reference list: download from our web site the enclosed list of drainage belts supplied till now for phosphoric acid application.

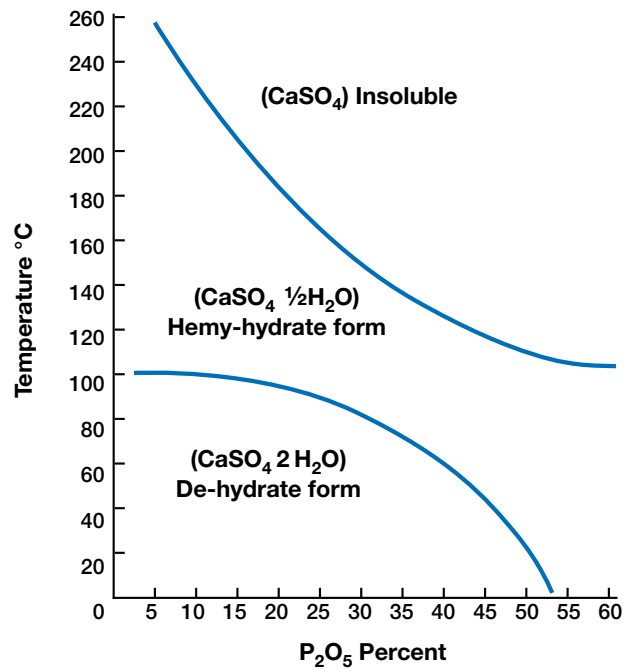



## WIDE DRAINAGE BELTS UP TO 4700 MM WIDTH

Our company invested in new technologies and equipment to be able to produce drainage belts up to 4700 mm wide, in order to meet the market demand of wider and wider drainage belts.



Moatize Coal - Mozambique

These belts are produced in two half parts and subsequently longitudinally sliced by hot vulcanization with a particular method that guarantees a lower decay in the values of breaking strength compared to the ones spliced with traditional technology. The result is a longitudinal junction without critical points and guaranteed over time.

All the belts are carefully checked before delivery, also through breaking elongation tests of rubber strips resulting from grooving, in order to verify the resistance of the longitudinal splice area.

Filterbelt up to 4700 mm width can be supplied both in open rolls, to be spliced at site, and endless with hot vulcanization splice carried out in our workshop. Feel free to contact us for any further details.

A crew of skilled technicians is always available to install our drainage belts all over the world.

Reference list: download from our web site the list of wide drainage belts produced and supplied till now.



Alcoa - Australia

*customizing your needs.*



## ON SITE INSTALLATIONS AND REPLACEMENTS

Our company supplies a reliable service for installation of drainage belts all over the world: from Russia to South America, from Perù to Australia we are always available for every destination.

Skilled crews - and new ones are continuously trained - are able to supply service for the following operations:

- dismantling of the old drainage belt
- installation of the new one
- splice by hot vulcanization or cold bonding
- centering and tracking
- lateral sides trimming
- application of lateral curbs by cold bonding by means of specific cements or by hot vulcanization
- drilling holes
- final tracking and belt stabilization

Presses and tools are always ready to be shipped anywhere for execution of works on site.

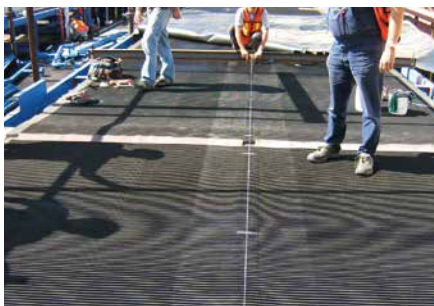
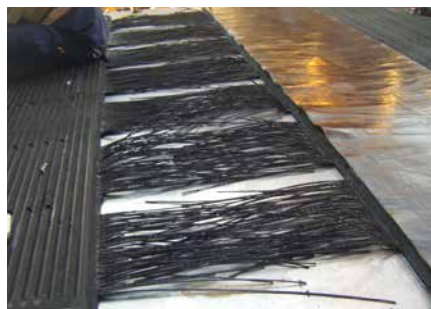

WIN WIN S.r.l.  
Cap. Soc. € 100.000,00 i.v.  
C.F.P.iva e Reg. Impr. CO 03289090130  
www.belts.com

Operational & Legal Address  
Via Risorgimento, 8  
22044 Inverigo (CO)  
Italy

Tel. +39 031.604111  
Fax. +39 031.604399  
info@belts.com

Drawing, materials and other data are subject to changes prior notice by WinWin S.r.l. All right reserved. Publication is protected by copyright and cannot be reproduced in any part without permission by the Company. Please, be aware that WinWin S.r.l. is the only owner of the know-how of former Cigo Industria Gomma S.r.l.